

INSTRUCTIONS AND THINGS TO MAKE

Ephrem's BOTTLE CUTTER KIT

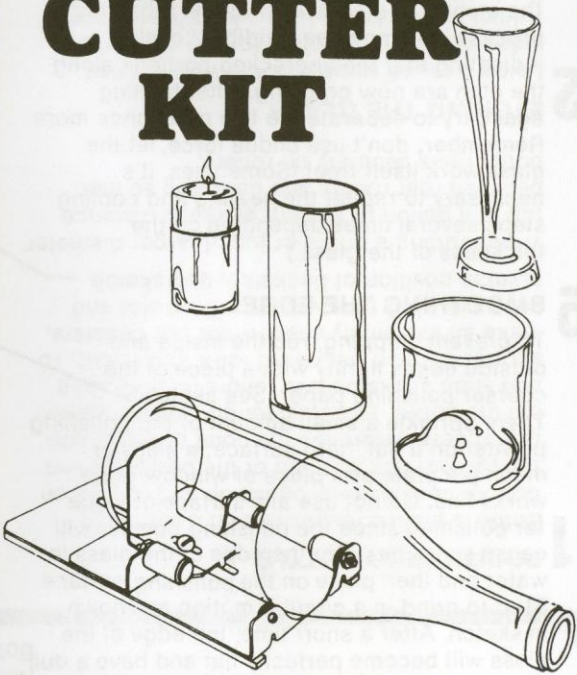

Ephrem's Bottleworks
 Box 210
 Cataract, WI 54620

CAUTION

ALWAYS wear eye protection while working with glass

ALWAYS remove the bottle cap before cutting and heating a bottle. Failure to do so may cause the bottle to explode during heating.

If unable to purchase these accessories from your local dealer, you may use this order blank. →

ORDER THESE ACCESSORIES FROM:
Ephrem's Bottleworks
 Box 210, Cataract, WI 54620

Please indicate quantity desired and amount of remittance enclosed. Send cash, check or money order - no stamps. Please include \$3.00 shipping and handling.

QUANTITY	PART NO.	DESCRIPTION	PRICE	ENCLOSED
	100P	Polishing Powder	\$2.00	\$
	200PP	Coarse & Fine Polishing Paper Combination Package	\$2.00	\$
	300C	Cutting Wheel	\$4.00	\$
	400B	Book: Introduction To Bottle Cutting	\$5.00	\$
	500A	Adaptor for Cutting Bottle Necks and Other Non-vertical Surfaces	\$6.00	\$
			POSTAGE	\$3.00
			TOTAL	\$

Allow 2-3 weeks for arrival of order

SEND TO: PLEASE PRINT

Name _____
 Address _____
 City _____ State _____ Zip _____

INSTRUCTIONS

IMPORTANT! Read CAUTIONS on back panel before proceeding.

Ephrem's Bottle Cutter Kit is completely assembled and ready to use.

Read the instructions carefully before attempting to cut a bottle. Remember, glass cutting is an art. Take your time and you will be rewarded by the excellence of the finished product.

Relax! If you're not successful with the first bottle, try another. Bottles are plentiful and easy to obtain.

1 POSITIONING BOTTLE

Bottle is placed lengthwise on Cutter with bottom flush against backstop and resting on the rollers. The position of the backstop and rear rollers determine the point at which you cut the bottle. To adjust length, loosen screw and slide backstop and rollers forward for a shorter cut and backward for a longer cut. To make an extremely shallow cut (for coasters, ashtrays, etc.) remove screw from slot and reverse position of backstop. See sketch.

When cutting a bottle or jug of larger diameter (up to a gallon or larger), increase distance between rear rollers and backstop so that bottle rests securely on rollers.

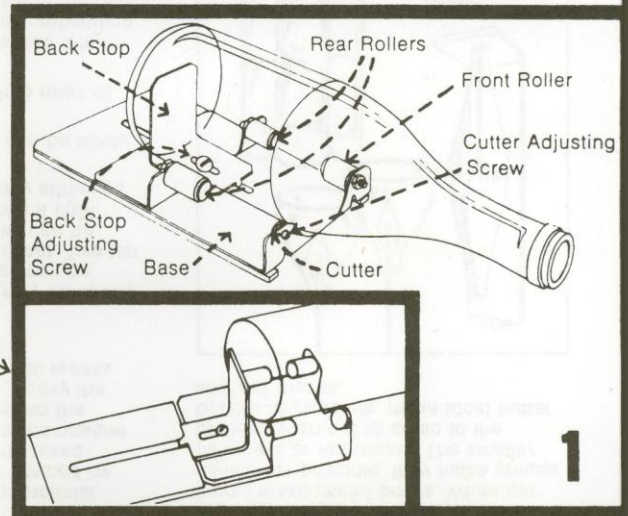

2 ETCHING THE GLASS

Using a round smooth bottle with parallel sides, select the location for the desired cut. Adjust the backstop to this length and place the bottle on the cutter as shown in sketch.

A light etch is all that is required. Apply only slight pressure on the bottle while rotating the bottle **toward you** with your hands. Note the position of the hands in sketch. To assure an accurate cut, keep the bottle firm against the backstop. Do not allow the bottle to stop turning while scribing the etch. A slight crunching sound will signal the completion of the etch. **ONE REVOLUTION OF THE BOTTLE IS ALL THAT IS NECESSARY.** Best results are obtained, and damage to the cutter wheel is avoided when the etch is not duplicated. If the etch is properly scribed the ends will meet.

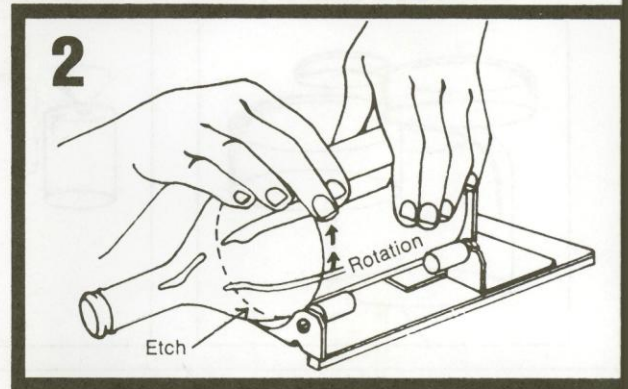

3 HEATING THE ETCH

Before the bottle can be separated, it first must be uniformly heated. Light the candle and **slowly** rotate the bottle in one direction with the tip of the flame about an eighth of an inch directly under the etch. Usually about three or four revolutions are sufficient.

Then rotate the bottle two or three times at a faster pace to give a final uniform temperature to the glass. The bottle should feel hot to the touch, but not too hot to handle.

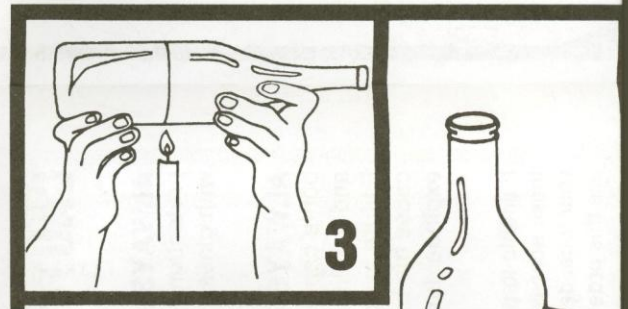

be uniformly heated. Light the candle and **slowly** rotate the bottle in one direction with the tip of the flame about an eighth of an inch directly under the etch. Usually about three or four revolutions are sufficient.

Then rotate the bottle two or three times at a faster pace to give a final uniform temperature to the glass. The bottle should feel hot to the touch, but not too hot to handle.

4 SEPARATING THE BOTTLE

Place bottle in an upright position and, before the bottle cools, rub an ice cube around the etched line one or more revolutions until the etch becomes a crack. Crack should continue completely around the bottle.

If a slight tug on the two pieces fails to separate them, **don't try** to force them apart. Return bottle to the candle flame and reheat the etch as in step 3. During this reheating process, you may hear audible "clicks" indicating that the uncracked portions along the etch are now cracking. After heating again, try to separate the two parts once more. **Remember**, don't use undue force, let the glass work itself free! (Sometimes, it's necessary to repeat the heating and cooling steps several times depending on the thickness of the glass.)

5 SMOOTHING THE EDGE

To prevent chipping, rub the inside and outside edges lightly with a piece of the coarser polishing paper. See sketch. Then, sprinkle a small amount of the polishing powder on a flat, hard surface; a glass or metal pie plate or a piece of window glass works fine. Do not use any surface of value for polishing since the polishing powder will cause scratches. Dip the edge of the glass in water and then place on the polishing surface. Start to grind in a circular motion as shown in sketch. After a short time, the edge of the glass will become perfectly flat and have a dull gray appearance. Again, smooth the inside and outside edges with the polishing paper.

The finer polishing paper should be used to give a final smooth finish. Use water on the paper periodically while polishing.

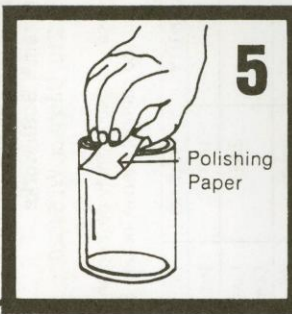
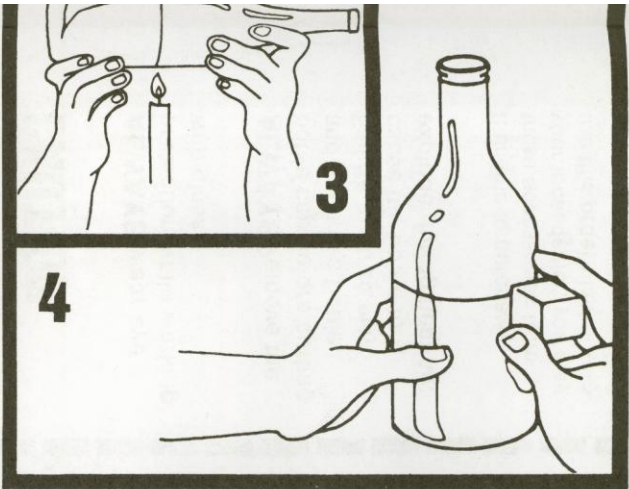

HELPFUL HINTS

- Brush some light machine oil on cutting wheel prior to cutting.
- The lighter the etch, the better the separation.
- For best results, keep the candle flame out of drafts.
- Do not cut over labels.
- The glass cutting wheel should always be at a right angle to the glass surface.
- When cutter seems dull, loosen cutter screw and turn wheel until new blade is in cutting position.
- If the bottle has a very large diameter (gallon size or larger) or very small diameter (not under 2 inches) loosen the cutting head screw and readjust the cutting wheel so that the top of the cutter fits against the glass (see sketch).

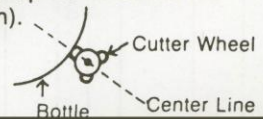

THINGS TO MAKE

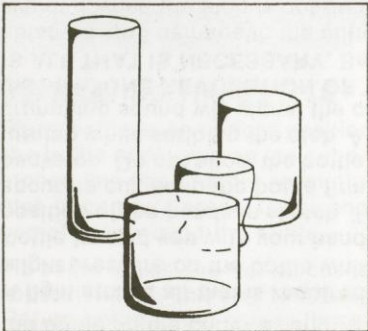

GLASSES OR VASES
of various heights

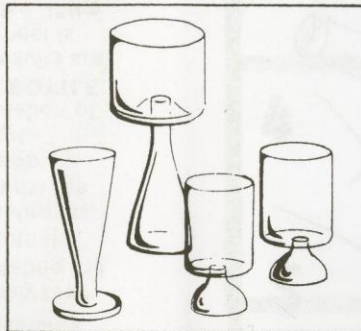

GOBLETS—cut bottle in half. Turn top half upside down and epoxy onto a stand of wood or other material. Exciting goblets can be created by cutting off the top of a recessed bottom bottle, such as a champagne bottle. Leave bottom section the desired length for bowl. Epoxy the neck of the same bottle into recess, to make stem and base.

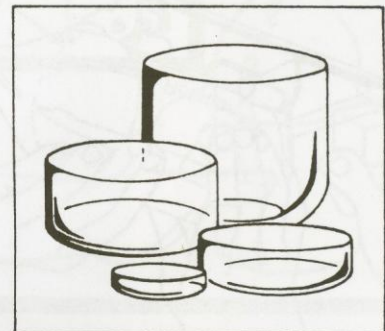

BOWLS, BUTTER & DIP DISHES—large diameter bottles (½ gal. or more) make useful bowls. When cut as high as possible, they make unique fishbowls or terrariums. The smaller bottles, when cut as close to the bottom as possible, make ideal butter and dip dishes.



CANDLE HOLDERS AND HURRICANE LAMPS

Most bottle tops make fine Candle Holders. Cut the top half off bottle and turn upside down so candle can be inserted in neck. For base, epoxy neck to a shallow bottom section cut from same size or smaller bottle.

The bottom half of a smaller bottle can be used to hold wax and wick for a Hurricane Lamp effect. For a base, the globe can be epoxied to the bottom cut from a larger bottle.

A Candle Stick can be made by cutting the top section from a jug with a handle. Insert candle in neck.

LIGHT FIXTURES

The top half of a bottle may be strung with a light bulb. Several may be combined for a cluster effect. Two top halves of identical bottles can be hinged together to contain a light source and result in a very attractive wall light.

Beautiful Lamp Shades can be made from bottles:

- A) Cut several bottles into rings of assorted sizes.
- B) Split the rings into halves lengthwise. This is done by freehanding an etch lengthwise along the ring, then tapping from the inside opposite the etch.
- C) Glue the split rings together with grey silicone glue to build the lamp shade.

HOOR GLASS

A unique contemporary Hour Glass can be made by epoxying two top halves of identical bottles mouth to mouth and adding top and bottom pieces of wood or metal.

